

Raised Panel Hogging Cutter

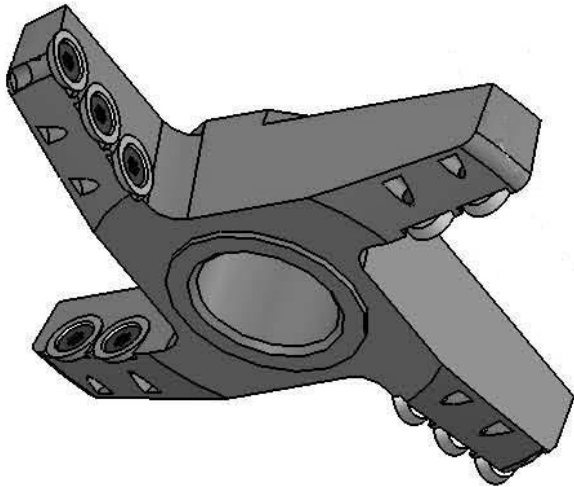

FACE UP

(2 Wing Effective Cut - 6" OD - 1 1/4" Bore)

Part Number	Description
CSTRP6H	Raised Panel Hogger
ICK8005	13.5x2.5 Round Insert for above

10 inserts per cutterhead

Spoil Board Cutters



STRAIGHT (for MDF and Particleboard)

Part Number	Cutting Diameter	Cutting Length	Shank Diameter	# of Wings
CST252ST	2 1/2"	1/2"	1/2"	2
CST42ST	4"	1/2"	3/4"	2
CST43ST	4"	1/2"	3/4"	3

UP-SHEAR (for Balsa Core Material)

Part Number	Cutting Diameter	Cutting Length	Shank Diameter	# of Wings
CST252SH	2 1/2"	1/2"	1/2"	2
CST42SH	4"	1/2"	3/4"	2
CST43SH	4"	1/2"	3/4"	3

Part Number	Description
ICK7007	14 x 14 x 2 inserts - 10 per pack
1200014	M5 x 7 screw for spoilboard cutter
1100014	T15 x 80 Torx Wrench for spoilboard cutter insert

CNC Router Table Pods



Part Number	Diameter	Height
CST P100 POD	1 3/4"	1"
CST P101 POD	1 3/4"	1 1/2"
CST P102 POD	1 3/4"	2"
CST P103 POD	1 3/4"	2 1/2"
CST P104 POD	1 3/4"	3"
CST P300 POD	3"	1"
CST P301 POD	3"	1 1/2"
CST P302 POD	3"	2"
CST P303 POD	3"	2 1/2"
CST P304 POD	3"	3"

Includes O-Rings
Black Nylon Material
Yellow or White Nylon available