

Carbide-Tipped Core Box Bits



1/4" SHANK BITS

Part Number	Cutting Diameter	Radius	Cutting Length	Overall Length
*CRV275	1/8"	1/16"	5/16"	2"
*CRV277	3/16"	3/32"	3/8"	2"
*CRV279	1/4"	1/8"	1/4"	2"
C1402	1/4"	1/8"	1/2"	1 3/4"
C1403	3/8"	3/16"	1/2"	1 3/4"
C1404	1/2"	1/4"	1/2"	1 3/4"
C1405	5/8"	5/16"	3/8"	2"
C1406	3/4"	3/8"	5/8"	1 7/8"

Carbide-Tipped Roundnose Bits



1/2" SHANK BITS

Part Number	Cutting Diameter	Radius	Cutting Length	Overall Length
C1405A	5/8"	5/16"	1/2"	2 1/4"
C1406A	3/4"	3/8"	5/8"	2 3/8"
C1406B	7/8"	7/16"	3/4"	2 1/2"
C1406C	1"	1/2"	3/4"	2 1/2"
C1407	3/8"	3/16"	1"	2 5/8"
C1408	1/2"	1/4"	1 1/4"	2 7/8"
C1410	5/8"	5/16"	1 1/4"	2 7/8"
C1411	3/4"	3/8"	1 1/4"	2 3/4"
C1412	7/8"	7/16"	1 1/4"	2 7/8"
C1413	1"	1/2"	1 1/4"	2 3/4"
C1414	1 1/4"	5/8"	1 1/4"	3"
C1415	1 1/2"	3/4"	1 1/4"	3"
C1416	1 3/4"	7/8"	1 1/4"	3"
C1417	2"	1"	1 1/4"	3"

Carbide-Tipped Roundnose Template Bits



1/4" SHANK BITS

Part Number	Cutting Diameter	Radius	Cutting Length	Overall Length
C1404B	1/2"	1/4"	1/2"	1 3/4"
C1406BB	3/4"	3/8"	5/8"	1 7/8"

Carbide-Tipped Half-Round (Bullnose) Bits

1/4" SHANK BITS

Part Number	Cutting Diameter	Radius	Cutting Length	Overall Length
C1425	3/16"	3/32"	1/4"	1 3/4"
C1426	1/4"	1/8"	5/8"	1 7/8"
C1427	3/16"	3/8"	1/4"	2"
C1428	1/2"	1/4"	7/8"	2 1/8"

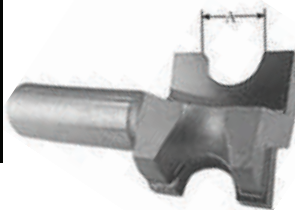

1/2" SHANK BITS

Part Number	Cutting Diameter	Radius	Cutting Length	Overall Length
C1430	1/4"	1/8"	5/8"	1 7/8"
C1431	3/8"	3/16"	11/16"	2 3/16"
C1432	1/2"	1/4"	7/8"	2 3/8"
C1433	3/4"	3/8"	1 1/8"	2 5/8"
C1434	1"	1/2"	1 3/8"	2 7/8"
C1435	1 1/4"	5/8"	1 3/4"	3 1/4"
C1436	1 1/2"	3/4"	1 7/8"	3 3/8"

Carbide-Tipped Hand-Grip Bits

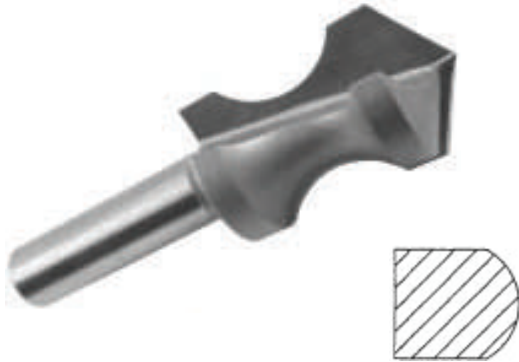

Part Number	Cutting Diameter	Cutting Depth	Cutting Length	Shank	Overall Length	Flutes
C1440	7/8"	1/4"	1 5/8"	1/2"	3 1/2"	2
*C1440B	7/8"	1/4"	1 5/8"	1/2"	3 1/2"	2

*Use CBE150 bearing w/collar for template guide routing.

Carbide-Tipped V-Groove Bits (90° Angle)

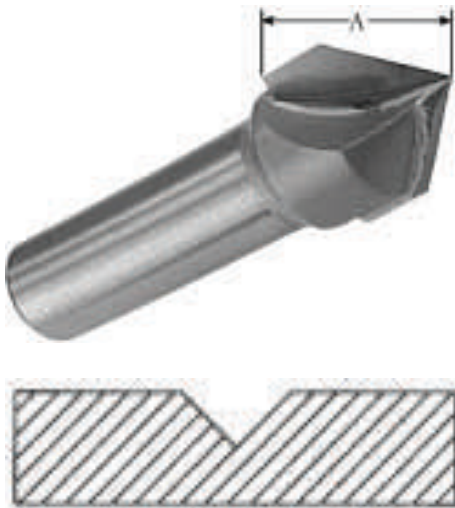

Part Number	Cutting Diameter	Cutting Length	Included Angle	Shank	Overall Length	Flutes
*CVG-260	1/4"	1/2"	90°	1/4"	1 1/2"	1
C1501	3/8"	1/2"	90°	1/4"	1 3/4"	2
C1502	1/2"	1/2"	90°	1/4"	1 3/4"	2
C1502A	5/8"	5/8"	90°	1/4"	2"	2
C1502B	3/4"	5/8"	90°	1/4"	2"	2
C1503	1/2"	1/2"	90°	1/2"	2 1/4"	2
C1504	3/4"	5/8"	90°	1/2"	2 1/2"	2
C1505	1"	3/4"	90°	1/2"	2 3/4"	2
C1507	1 1/2"	1"	90°	1/2"	2 1/2"	2
C1508	2"	1 1/2"	90°	1/2"	2 3/4"	2

Carbide-Tipped V-Groove Bits (60° Angle)

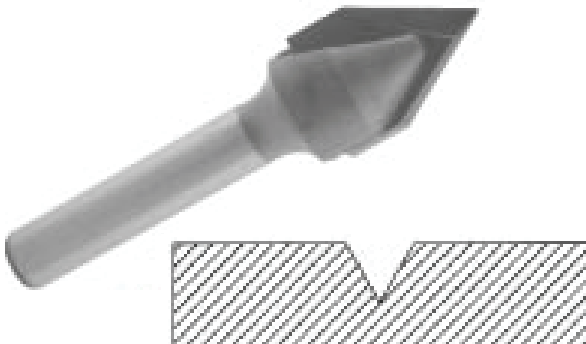

Part Number	Cutting Diameter	Cutting Length	Included Angle	Shank	Overall Length	Flutes
*SCVG264	1/4"	7/32"	60°	1/4"	1-1/2"	1
*C1541	1/4"	7/32"	60°	1/4"	2"	3
C1550	1/2"	5/8"	60°	1/4"	2"	2
C1560	1/2"	7/16"	60°	1/2"	2-1/4"	2

*Solid carbide.

Carbide-Tipped Specialty Molding Bits

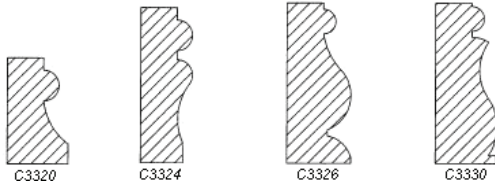
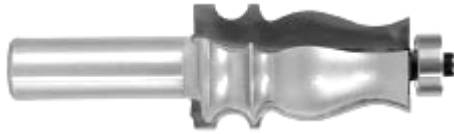

Part Number	Bead Diameter	Large Diameter	Cutting Length	Shank Diameter	Overall Length
C3320	5/16"	1"	7/8"	1/2"	2 1/2"
C3324	5/16"	15/16"	1 3/8"	1/2"	3"
C3326	1/4"	1 1/16"	1 5/8"	1/2"	3 1/4"
C3330	1/4"	1"	1 11/16"	1/2"	3 5/16"

CB3 Bearing

Carbide-Tipped Classic Multi-form Bits

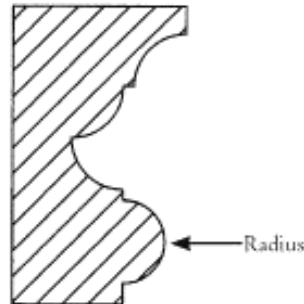

Part Number	Radius	Large Diameter	Cutting Length	Shank Diameter
C3342	7/32"	2 1/4"	1 7/8"	1/2"

Carbide-Tipped Plunge Ogee Bits



Part Number	Radius	Cutting Diameter	Cutting Length	Shank Diameter
C3601	1/16"	3/8"	3/8"	1/4"
C3602	3/32"	1/2"	3/8"	1/4"
C3603	1/8"	3/4"	7/16"	1/4"
C3604	3/16"	7/8"	1/2"	1/4"
C3605	1/16"	3/8"	3/8"	1/2"
C3605A	3/32"	1/2"	3/8"	1/2"
C3605B	1/8"	3/4"	7/16"	1/2"
C3606	3/16"	7/8"	5/8"	1/2"
C3608	3/16"	1 1/4"	11/16"	1/2"

Carbide-Tipped Classical Round Bottom Bits



Part Number	Radius	Large Diameter	Cutting Length	Shank Diameter
C3719	3/32"	1/2"	3/8"	1/4"
C3728	5/32"	3/4"	1/2"	1/4"
C3733	5/32"	3/4"	1/2"	1/2"
C3738	7/32"	1"	5/8"	1/2"
C3752	3/8"	1 1/2"	3/4"	1/2"

Carbide-Tipped MDF Door Bits



Part Number	Large Diameter	Style	Overall Length	Shank Diameter
C5610	7/8"	Bead	2 1/2"	1/2"
C5620	1 1/4"	Traditional	2 1/2"	1/2"
C5710	1 1/2"	Cove	2 1/2"	1/2"
C5720	1 1/2"	Straight	2 1/2"	1/2"
C5725	1 1/2"	Ogee	2 1/2"	1/2"

See page 7 for these same tools in diamond tipped.

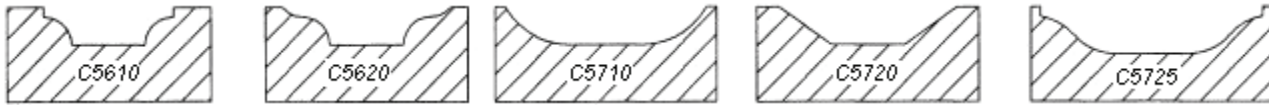

Carbide-Tipped Vertical Panel Bits



Part Number	Cutting Diameter	Cutting Length	Style	Shank Diameter
C5801	1"	1 1/2"	Cove	1/2"
C5802	1"	1 1/2"	Straight	1/2"
C5804	1"	1 1/2"	Ogee	1/2"
C5805	1"	1 1/2"	Ogee Bead	1/2"

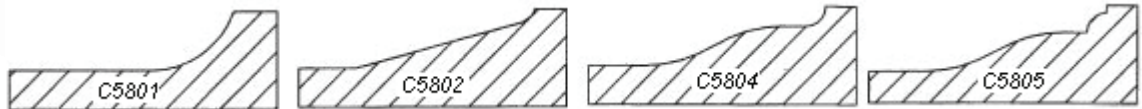

Carbide-Tipped Raised Panel Bits



Part Number	Cutting Diameter	Cutting Depth	Style	Shank Diameter
C5900B	3 1/4"	1 3/8"	Cove	1/2"
C5900E	3 1/4"	1 3/8"	Straight	1/2"
C5900H	3 1/4"	1 3/8"	Ogee	1/2"

CB3 Bearing

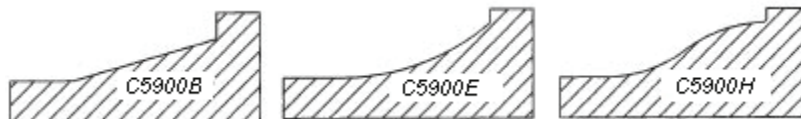

Carbide-Tipped Dovetail Bits



Part Number	Cutting Diameter	Cutting Length	Shank	Overall Length	Angle	Use
C1601	7/8"	5/8"	1/2"	2 1/2"	3°	Stair Treads
C1625	5/8"	7/8"	1/2"	2-5/8"	7°	Incra™
C1635	3/4"	7/8"	1/2"	2-3/4"	7°	Incra™
C1635LH	3/4"	7/8"	1/2"	2-3/4"	7°	Incra™
C1645	7/8"	7/8"	1/2"	2-3/4"	7°	Stair Treads
C1645LH	7/8"	7/8"	1/2"	2-3/4"	7°	Stair Treads
*CDT7525	1/4"	5/16"	1/4"	2"	7 1/2°	Incra™/Omni Jig
C1661	5/16"	3/8"	1/4"	2 1/4"	8°	Leigh™ #60
C1662	3/8"	1/2"	1/4"	2 3/8"	8°	Leigh™ #70
C1663	7/16"	13/16"	1/4"	2 3/8"	8°	Leigh™ #75
C1664	1/2"	13/16"	1/4"	2 3/4"	8°	Leigh™ #80
C1666	11/16"	1"	1/2"	3"	8°	Leigh™ #90
C1668	13/16"	1-1/4"	1/2"	3 1/4"	8°	Leigh™ #100
C1605	3/8"	3/8"	1/4"	2 1/4"	9°	Incra™
C1613	3/8"	3/8"	3/8"	2"	9°	
C1615	3/8"	3/8"	1/2"	2 1/2"	9°	
C1615LH	3/8"	3/8"	1/2"	2 1/2"	9°	Incra™
C1618	.390"	3/8"	1/2"	2"	9°	
C1618LH	.390"	3/8"	1/2"	2"	9°	
C1672	1/2"	5/8"	1/4"	2 1/2"	10°	Incra™/Leigh #101
C1674	1/2"	5/8"	1/2"	2 5/8"	10°	Incra™
C1611	3/8"	3/8"	1/4"	2"	14°	
C1610	1/2"	1/2"	1/4"	2"	14°	Incra™/Omni Jig
C1622	1/2"	1/2"	1/4"	2 3/8"	14°	Leigh #120
C1620	1/2"	1/2"	1/2"	2 1/2"	14°	Incra™/Omni Jig
C1630	3/4"	3/4"	1/2"	3"	14°	Omni Jig
C1640	1"	7/8"	1/2"	2 1/2"	14°	
C1680	1/2"	3/8"	1/4"	2 1/4"	18°	Leigh #128

*Solid Carbide - LH proceed Part # - Lefthand

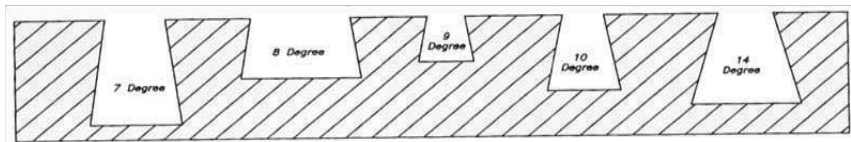

Carbide-Tipped Panel Pilot Bits

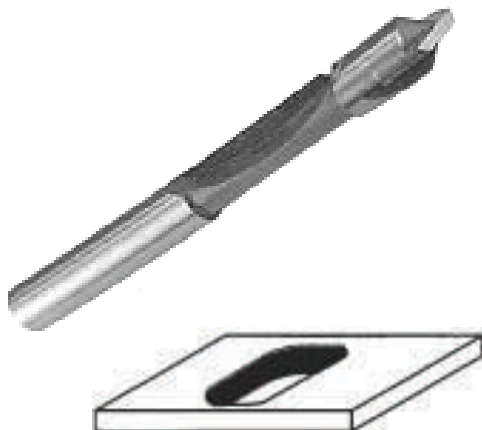

Part Number	Cutting Diameter	Cutting Length	Shank	Overall Length	Flutes
C1700	1/4"	3/4"	1/4"	2 1/2"	1
C1701	3/8"	1"	3/8"	2 7/8"	1
C1701-N	3/8"	1"	3/8"	2 7/8"	1
C1702	1/2"	1-3/16"	1/2"	3 1/2"	1
C1702-N	1/2"	1-3/16"	1/2"	3 1/2"	1
C1703	1/2"	2"	1/2"	4 1/8"	1
C1704	3/8"	1"	1/4"	3 1/4"	2
C1705	3/8"	1"	3/8"	3"	2
C1706	1/2"	1 3/16"	1/2"	3 1/2"	2

C1701-N & C1702-N have special carbide designed for nail and staple cutting.

Carbide-Tipped Center Pilot Stagger Bits



Part Number	Cutting Diameter	Cutting Length	Shank	Overall Length
C1725	1/2"	2-3/4"	1/2"	4-1/4"
C1726	1/2"	2 3/4"	1/2"	4 1/4"

The C1726 is used for CNC and very harsh applications where tool life is needed.

Carbide-Tipped Cove Bits

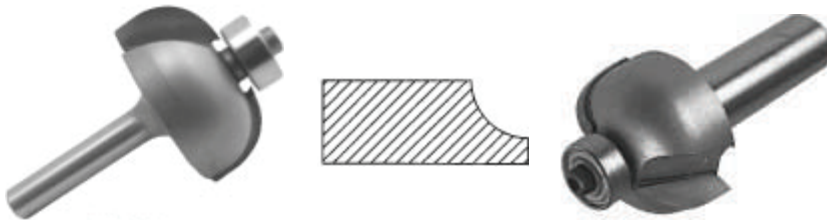

Part Number	Radius	Cutting Diameter	Cutting Length	Shank
C1800B	1/8"	3/4"	1/2"	1/4"
C1800A	3/16"	7/8"	1/2"	1/4"
C1800	1/4"	1"	1/2"	1/4"
C1801A	5/16"	1 1/8"	1/2"	1/4"
C1801	3/8"	1-1/4"	1/2"	1/4"
C1802	1/2"	1-1/2"	5/8"	1/4"
C1803A	3/16"	7/8"	1/2"	1/2"
C1803	1/4"	1"	1/2"	1/2"
C1804A	5/16"	1-1/8"	1/2"	1/2"
C1804	3/8"	1-1/4"	1/2"	1/2"
C1805	1/2"	1-1/2"	5/8"	1/2"
C1806	5/8"	1-3/4"	3/4"	1/2"
C1807	3/4"	2"	1"	1/2"
C1810	1"	2-1/2"	1-1/4"	1/2"

Use CB3 bearing

Carbide-Tipped Rabbet Bits



Part Number	Cutting Diameter	Cutting Length	Cutting Depth	Shank	Overall Length
C1900	1-1/4"	1/2"	3/8"	1/4"	2 1/8"
C1901	1-1/4"	1/2"	3/8"	1/2"	2 3/8"
C1951	1 3/8"	1/2"	1/2"	1/4"	2 3/8"
C1954	1 3/8"	1/2"	1/2"	1/2"	2 1/2"
C1962	2"	1"	3/4"	1/2"	2 7/8"

For different depths of cut, see kits below.

RABBETING BIT KITS

Includes C1900 (1/4" Shank) or C1901 (1/2" Shank) Bit and 3 additional bearings for multiple depths of 7/16", 3/8", 5/16" and 1/4".

Part Number	Description
C1902	1/4" Shank Set
C1903	1/2" Shank Set

Includes C1962 Bit and 7 additional bearings for multiple depths of 13/16", 3/4", 11/16", 5/8", 19/32", 21/32", 9/16" and 1/2"

Part Number	Description
C1965	1/2" Shank Only

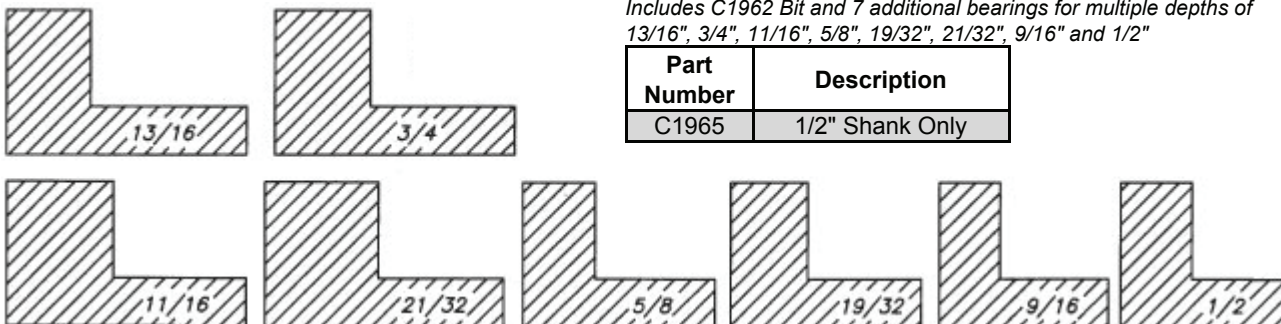

Carbide-Tipped Slotting Bits



2 FLUTE

Part Number	Cutting Diameter	Cutting Length	Cutting Depth	Shank Diameter
C1904	1 1/4"	1/8"	3/8"	1/4"
C1908	1 1/2"	5/32"	1/2"	1/4"
C1912	1 1/4"	1/4"	3/8"	1/4"
C1916	1 1/4"	3/8"	3/8"	1/4"
C1920	1 1/2"	1/2"	1/2"	1/4"
C1906	1 1/4"	1/8"	3/8"	1/2"
C1910	1 1/2"	5/32"	1/2"	1/2"
C1914	1 1/4"	1/4"	3/8"	1/2"
C1917	1 1/4"	5/16"	3/8"	1/2"
C1918	1 1/4"	3/8"	3/8"	1/2"
C1922	1 1/2"	1/2"	1/2"	1/2"
C1924	1 1/4"	3/4"	3/8"	1/2"

3 FLUTE - FOR TYLER® MACHINE

Part Number	Cutting Diameter	Cutting Length	Cutting Depth	Shank Diameter
SE1980	1 1/8"	3/16"	5/16"	3/8"

Use CBE115 Bearing

Carbide-Tipped Roundover Bits



Part Number	Radius	Cutting Diameter	Cutting Length	Shank Diameter
C2000A	1/16"	5/8"	1/2"	1/4"
C2000C	1/8"	3/4"	1/2"	1/4"
C2000D	5/32"	13/16"	1/2"	1/4"
C2000	3/16"	7/8"	1/2"	1/4"
C2001	1/4"	1"	1/2"	1/4"
C2002	5/16"	1-1/8"	1/2"	1/4"
C2003	3/8"	1-1/4"	5/8"	1/4"
C2003A	7/16"	1 3/8"	11/16"	1/4"
C2004	1/2"	1-1/2"	3/4"	1/4"
C2005A	1/8"	3/4"	1/2"	1/2"
C2005	3/16"	7/8"	1/2"	1/2"
C2006	1/4"	1"	1/2"	1/2"
C2007	5/16"	1-1/8"	1/2"	1/2"
C2008	3/8"	1-1/4"	5/8"	1/2"
C2008A	7/16"	1 3/8"	11/16"	1/2"
C2009	1/2"	1-1/2"	3/4"	1/2"
C2009B	9/16"	1-3/4"	1"	1/2"
C2009A	5/8"	1-3/4"	3/4"	1/2"
C2010	3/4"	2"	1"	1/2"
C2011	7/8"	2-1/4"	1-1/8"	1/2"
C2012	1"	2-1/2"	1-5/16"	1/2"
C2013	1 1/8"	3"	1 1/2"	1/2"
*C2014	1 1/4"	3 1/4"	1 3/4"	1/2"
C2015	1 3/8"	3 1/2"	1 3/4"	1/2"
*C2016	1-1/2"	3-3/4"	1-7/8"	1/2"

Roundovers without asterisk use CB3 Bearing and CDS115 Dust Shield

*Roundovers with asterisk use CB4 Bearing and CDS120 Dust Shield

Phone: 866-770-8665 - www.carolinatools.com - Fax: 866-418-8665

Carbide-Tipped Plunge Roundover Bits

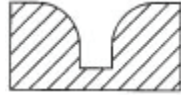

Part Number	Radius	Large Diameter	Small Diameter	Cutting Length	Shank Diameter
C2050	1/8"	3/8"	1/8"	1/4"	1/4"
C2051	3/16"	5/8"	1/4"	1/8"	1/4"
C2052	1/4"	3/4"	1/4"	3/8"	1/4"
C2055	1/4"	3/4"	1/4"	1/4"	1/2"
C2056	1/4"	3/4"	1/4"	3/8"	1/2"
C2057	3/8"	1"	1/4"	5/16"	1/2"
C2058	3/8"	1"	1/4"	1/2"	1/2"
C2060	1/2"	1-3/8"	3/8"	3/4"	1/2"
C2062	9/16"	1-5/8"	1/2"	1"	1/2"
C2066	3/4"	2"	1/2"	1-1/8"	1/2"

Carbide-Tipped Plunge Roundover Edge Trim Bits



Part Number	Radius	Large Diameter	Small Diameter	Cutting Length	Shank Diameter
C2068	3/16"	1"	1/2"	1 3/16"	1/2"
C2070	3/16"	1"	1/2"	1 5/16"	1/2"
C2072	1/4"	1-1/8"	1/2"	1 3/16"	1/2"
C2074	1/4"	1-1/8"	1/2"	1 5/16"	1/2"
C2076	3/8"	1-3/8"	1/2"	1 3/16"	1/2"
C2078	3/8"	1-3/8"	1/2"	1 5/16"	1/2"

Carbide-Tipped Beading Bits



Part Number	Radius	Cutting Diameter	Cutting Length	Shank Diameter
CBE2000A	1/16"	5/8"	1/2"	1/4"
CBE2000C	1/8"	3/4"	1/2"	1/4"
CBE2000D	5/32"	13/16"	1/2"	1/4"
CBE2000	3/16"	7/8"	1/2"	1/4"
CBE2001	1/4"	1"	1/2"	1/4"
CBE2002	5/16"	1-1/8"	1/2"	1/4"
CBE2003	3/8"	1-1/4"	5/8"	1/4"
CBE2003A	7/16"	1 3/8"	11/16"	1/4"
CBE2004	1/2"	1-1/2"	3/4"	1/4"
CBE2005A	1/8"	3/4"	1/2"	1/2"
CBE2005	3/16"	7/8"	1/2"	1/2"
CBE2006	1/4"	1"	1/2"	1/2"
CBE2007	5/16"	1-1/8"	1/2"	1/2"
CBE2008	3/8"	1-1/4"	5/8"	1/2"
CBE2008A	7/16"	1 3/8"	11/16"	1/2"
CBE2009	1/2"	1-1/2"	3/4"	1/2"
CBE2009B	9/16"	1-3/4"	1"	1/2"
CBE2009A	5/8"	1-3/4"	3/4"	1/2"
CBE2010	3/4"	2"	1"	1/2"
CBE2011	7/8"	2-1/4"	1-1/8"	1/2"
CBE2012	1"	2-1/2"	1-5/16"	1/2"
*CBE2013	1 1/8"	3"	1 1/2"	1/2"
*CBE2014	1 1/4"	3 1/4"	1 3/4"	1/2"
*CBE2015	1 3/8"	3 1/2"	1 3/4"	1/2"
*CBE2016	1-1/2"	3-3/4"	1-7/8"	1/2"

Beading Bits without asterisk use CB3 Bearing and CDS115 Dust Shield
 *Beading Bits with asterisk use CB4 Bearing and CDS120 Dust Shield

Carbide-Tipped Double Roundover Bits



Part Number	Radius	Large Diameter	Overall Length	Shank Diameter
C2160	1/8"	1 1/8"	3 3/4"	1/2"
C2162	3/16"	1 1/4"	3 3/4"	1/2"
C2164	1/4"	1 3/8"	3 3/4"	1/2"

CB125 Bearing

Carbide-Tipped Roman Ogee Bits



Part Number	Radius	Cutting Diameter	Cutting Length	Shank Diameter
C2200	5/32"	1 1/8"	9/16"	1/4"
C2201	1/4"	1 1/2"	11/16"	1/4"
C2202	5/32"	1 1/8"	9/16"	1/2"
C2203	1/4"	1 1/2"	11/16"	1/2"
C2210	3/8"	2"	1"	1/2"

CB3 Bearing

Carbide-Tipped Edge Bevel/Laminate Trim Bits



Part Number	Degree	Cutting Diameter	Cutting Length	Shank Diameter
C2298	7°	3/8"	3/8"	1/4"
C2300	15°	1/2"	1/2"	1/4"
C2300A	15°	1/4"	1/4"	1/4"
C2300B	22°	3/8"	3/8"	1/4"
C2301	25°	7/16"	1/2"	1/4"
C2308A	30°	3/8"	7/16"	1/4"
C2302	45°	7/16"	5/8"	1/4"
C2305	22 1/2°	3/8"	3/8"	1/2"
C2307	22 1/2°	7/8"	15/16"	1/2"
C2309	30°	3/4"	7/8"	1/2"
C2305	45°	7/16"	5/8"	1/2"
C2306	45°	13/16"	1 1/8"	1/2"
C2310	45°	1 1/16"	1 1/2"	1/2"

CB3 Bearing

Carbide-Tipped Flush Trim (Double Bearing) Bits



Part Number	Cutting Diameter	Cutting Length	Overall Length	Shank Diameter	Flutes	Bearing
C2457	1/2"	1 1/2"	4"	1/2"	2	CB3
C2554	1/2"	1 1/2"	4"	1/2"	3	CB3
C2458	1/2"	2"	4 1/2"	1/2"	2	CB3
C2555	1/2"	2"	4 1/2"	1/2"	3	CB3

Carbide-Tipped Flush Trim Bits

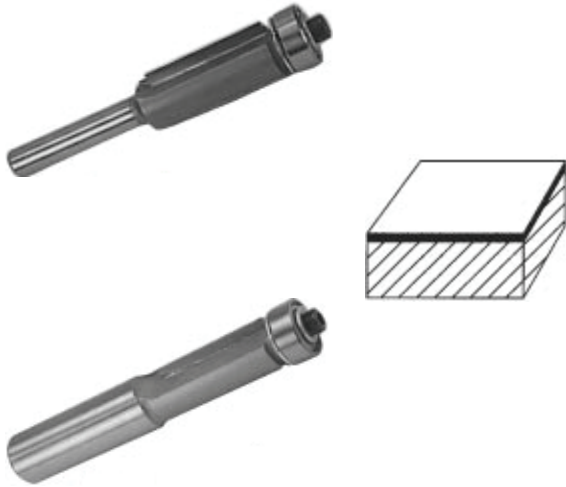

Part Number	Cutting Diameter	Cutting Length	Overall Length	Shank Diameter	Flutes	Bearing
C2400A	1/4"	3/4"	2 1/2"	1/4"	2	CB1A
C2400	3/8"	1"	2 3/4"	1/4"	2	CB1
C2401	3/8"	1/2"	2 1/4"	1/4"	2	CB1
C2403	1/2"	1/2"	2 3/8"	1/4"	2	CB3
C2501	1/2"	1/2"	2 3/8"	1/4"	3	CB3
C2402	1/2"	1"	2 3/4"	1/4"	2	CB3
C2500	1/2"	1"	2 3/4"	1/4"	3	CB3
C2404	1/2"	1 1/2"	3 1/4"	1/4"	2	CB3
C2406	1/2"	1/2"	2 3/4"	1/2"	2	CB3
C2405	1/2"	1"	3 1/8"	1/2"	2	CB3
C2502	1/2"	1"	3 1/8"	1/2"	3	CB3
C2407	1/2"	1 1/2"	3 3/4"	1/2"	2	CB3
C2504	1/2"	1 1/2"	3 3/4"	1/2"	3	CB3
C2408	1/2"	2"	4 1/8"	1/2"	2	CB3
C2505	1/2"	2"	4 1/8"	1/2"	3	CB3
C2409	3/4"	1"	3 3/8"	1/2"	2	CB3
C2410	3/4"	1 1/4"	3"	1/2"	2	CB4

Carbide-Tipped Flush Trim V-Groove Bits



Part Number	Cutting Diameter	Cutting Length	Overall Length	Shank Diameter	Flutes	Bearing
C2425	1/2"	1"	2 3/4"	1/4"	2	CB3
C2426	1/2"	1"	3 1/8"	1/2"	2	CB3

Carbide-Tipped Overhang Bits

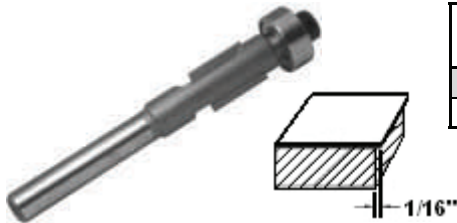

Part Number	Overhang	Cutting Diameter	Cutting Length	Overall Length	Shank Diameter	Flutes	Bearing
C2468	1/16"	3/8"	1/2"	2 5/8"	1/4"	2	CB3
C2470	1/8"	1"	1/2"	2 5/8"	1/4"	2	CB7

Carbide-Tipped Downshear Flush Trim Bits

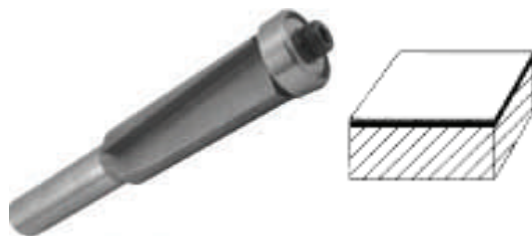

Part Number	Cutting Diameter	Cutting Length	Overall Length	Shank Diameter	Flutes	Bearing
C2562	3/8"	1"	2 5/8"	1/4"	2	CB3
C2560	3/4"	5/8"	2 1/8"	1/4"	2	CB3
C2570	3/4"	1"	3"	1/2"	2	CB3
C2575	3/4"	1 1/2"	3 1/2"	1/2"	2	CB3
C2580	3/4"	2"	4"	1/2"	2	CB3

Carbide-Tipped Template Bits

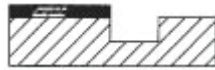

Part Number	Cutting Diameter	Cutting Length	Overall Length	Shank Diameter	Flutes	Bearing
C3000A	1/2"	1/8"	2"	1/4"	2	CB9
C3000	1/2"	1/4"	2 1/4"	1/4"	2	CB9
C3001	1/2"	1/2"	2 1/4"	1/4"	2	CB9
C3003	1/2"	3/4"	2 1/4"	1/4"	2	CB9
C3004	1/2"	1"	2 3/4"	1/4"	2	CB6
C3008	5/8"	1"	2 1/4"	1/4"	2	CB6
C3014	3/4"	1"	2 1/4"	1/4"	2	CB4
C3018	1-1/8"	1-1/2"	3-1/2"	1/2"	2	CB11
C3019	1 1/8"	2"	4"	1/2"	2	CB11
C3020	3/4"	1"	2-3/4"	1/2"	2	CB19
C3021	3/4"	1-1/4"	2 3/4"	1/2"	2	CB19
C3022	3/4"	1-1/2"	3"	1/2"	2	CB19
C3023	3/4"	2"	3 3/4"	1/2"	2	CB19

1/4" shank bits use 1/4" collar

1/2" shank bits use 1/2" collar

Carbide-Tipped Keyhole Bits



Part Number	Cutting Diameter	Cutting Length	Shank Diameter	Overall Length
C3050	3/8"	3/8"	1/4"	1 1/2"
C3052	1/2"	1/2"	1/4"	1 3/4"

Carbide-Tipped Drawer Lock Bits

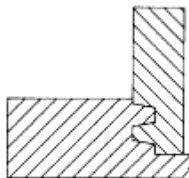

Part Number	Large Diameter	Cutting Length	Overall Length	Shank Diameter	Flutes
C3350	1 1/16"	3/4"	2 5/16"	1/4"	2
C3352	1 1/16"	3/4"	2 9/16"	1/2"	2

Carbide-Tipped Glue Joint Bits



Part Number	Large Diameter	Cutting Length	Overall Length	Shank Diameter	Flutes
C3354	1 1/2"	1 1/4"	3"	1/2"	2

Carbide-Tipped 45° Lock Miter Bits

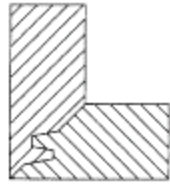

Part Number	Large Diameter	Cutting Length	Overall Length	Shank Diameter	Flutes
C3360	1 3/4"	3/4"	3"	1/2"	2
C3362	3 1/2"	1 5/8"	4"	1/2"	2

Carbide-Tipped Wedge Tongue & Groove Bits



C3370A

1/2" SHANK - 2 PIECE SET

Part Number	Material Thickness	Cutting Diameter	Cutting Length	Overall Length	Flutes
C3370	1/2"-1 1/8"	1 1/2"	1 1/8"	2 5/8"	2

To order individually:

C3370A - Tongue

C3370B - Groove



C3370B



Carbide-Tipped Tongue & Groove Assembly



1/2" SHANK

Part Number	Material Thickness	Cutting Diameter	Cutting Length	Bearing	Wings
C3375	1/2"-13/16"	1 5/8"	9/32"	SBE125	2

Replacement Parts:

C3375G - Slotting Cutter

CAR500-1 7/16 - Arbor

CB5 - Bearing

CSK-012 - Shim Kit

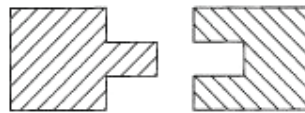

Carbide-Tipped Finger Joint Assembly



Part Number	Cutting Diameter	Cutting Length	Finger Depth	Shank Diameter	Wings
C3385	1 9/16"	1 1/4"	7/32"	1/2"	2

